

**SOLAR PANEL LAYOUTS - THREE STRINGS**

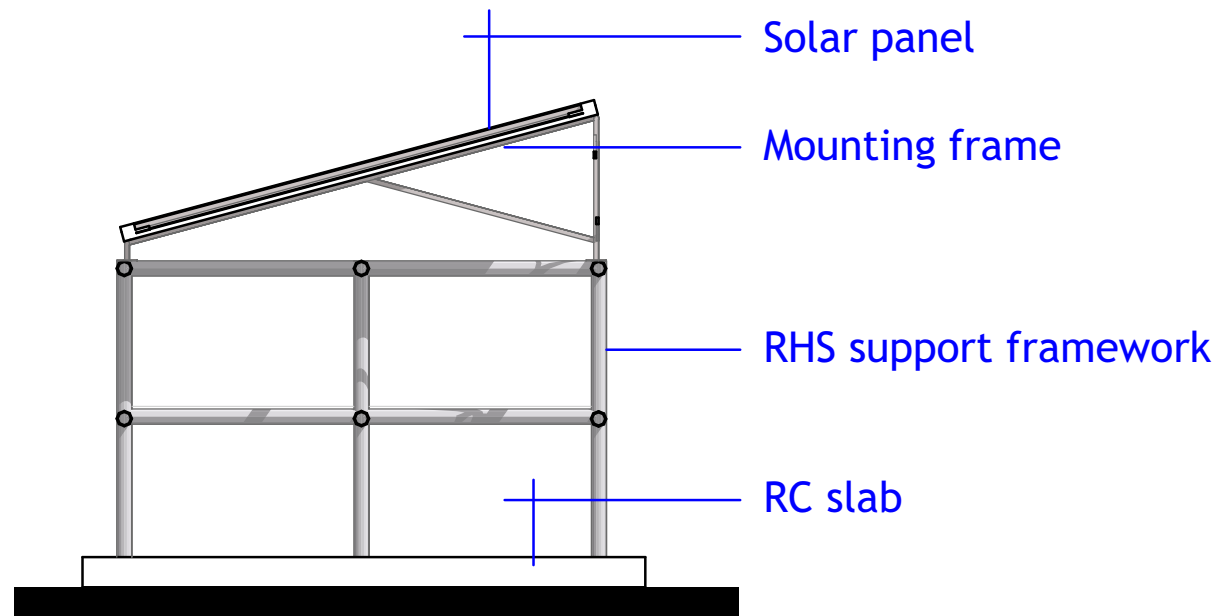

**SOLAR STRUCTURE ELEVATION**

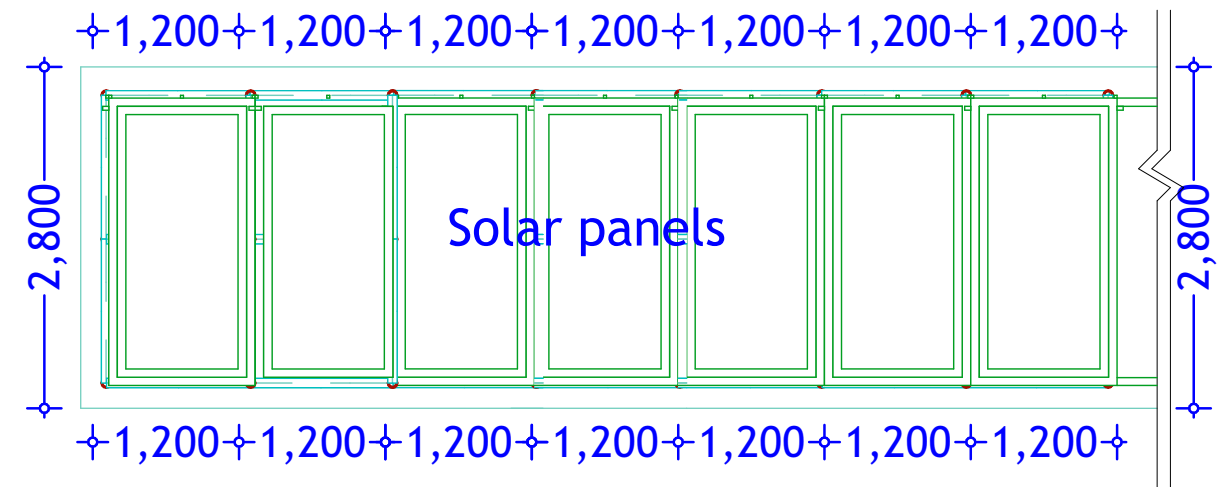

**TYPICAL 7 NO. PANEL LAYOUT**

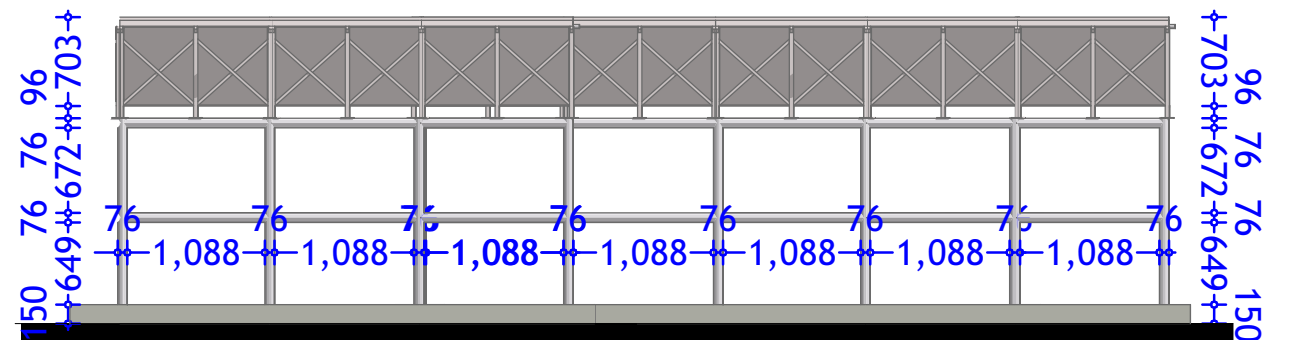

**SOLAR STRUCTURE ELEVATION**

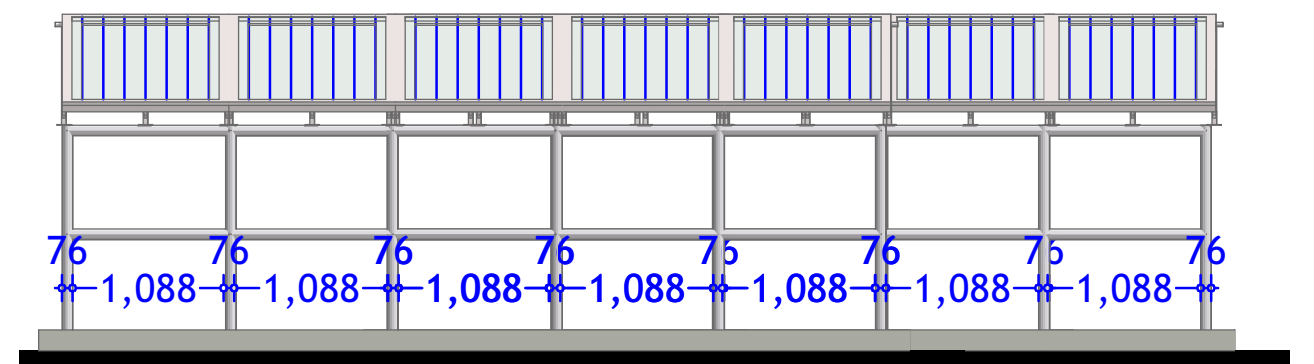

**SOLAR STRUCTURE ELEVATION**

**PROJECT**  
PROPOSED NEW BOREHOLE WORKS



**LOCATION**  
**WASH** SUPPORTED BENEFICIARY SITES IN SOMALIA

**DESCRIPTION**

REV.	DESCRIPTION	DATE

STATUS	NEW CONSTRUCTION
DATE	JAN 2020
DESIGNED BY:	ENG. WANJA D.
DRAWN BY:	ENG. WANJA D.
REVIEWED BY:	
APPROVED BY:	DR. O. KHYARE

DRAWING TITLE:	Details
DRAWING N°:	
PROJECT N°:	

**BOREHOLES**

SHEET N°:

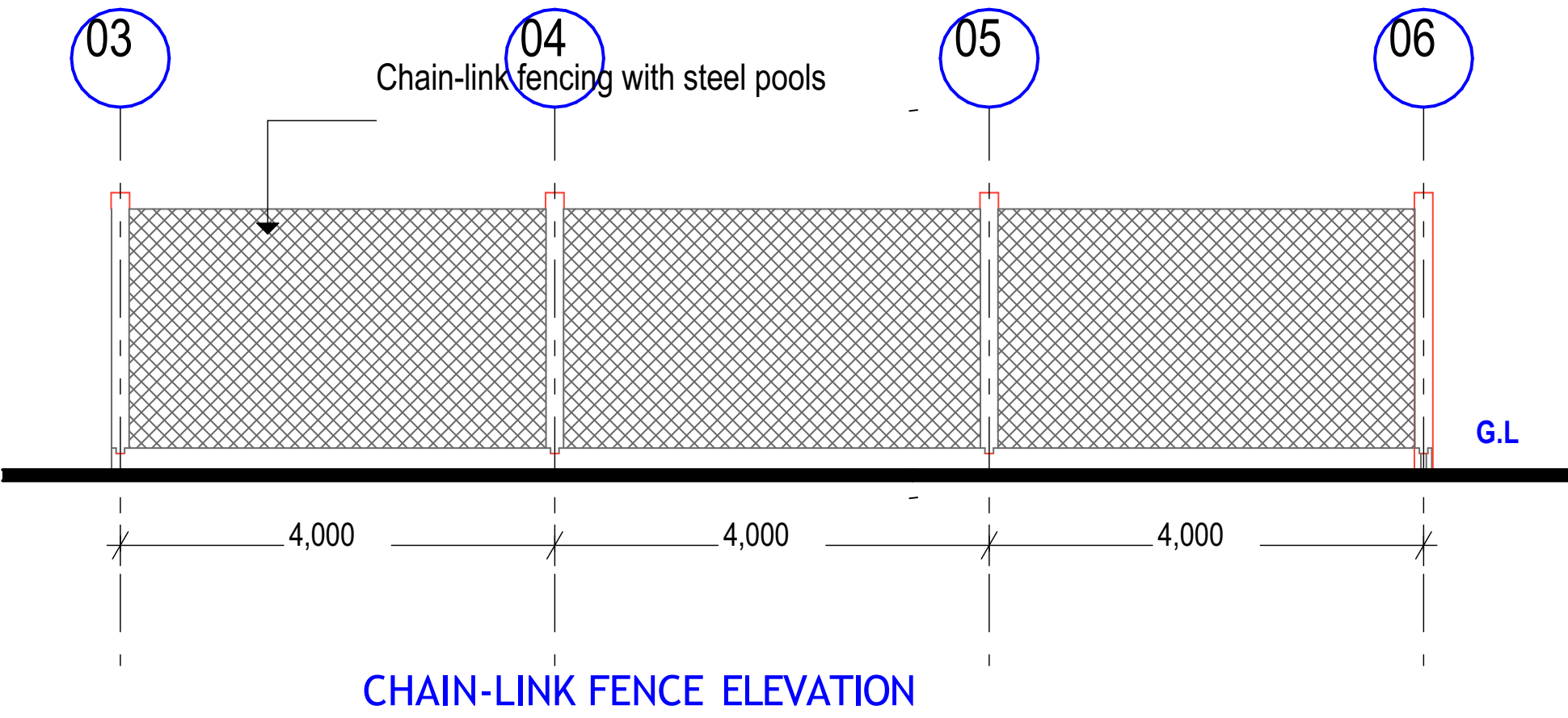
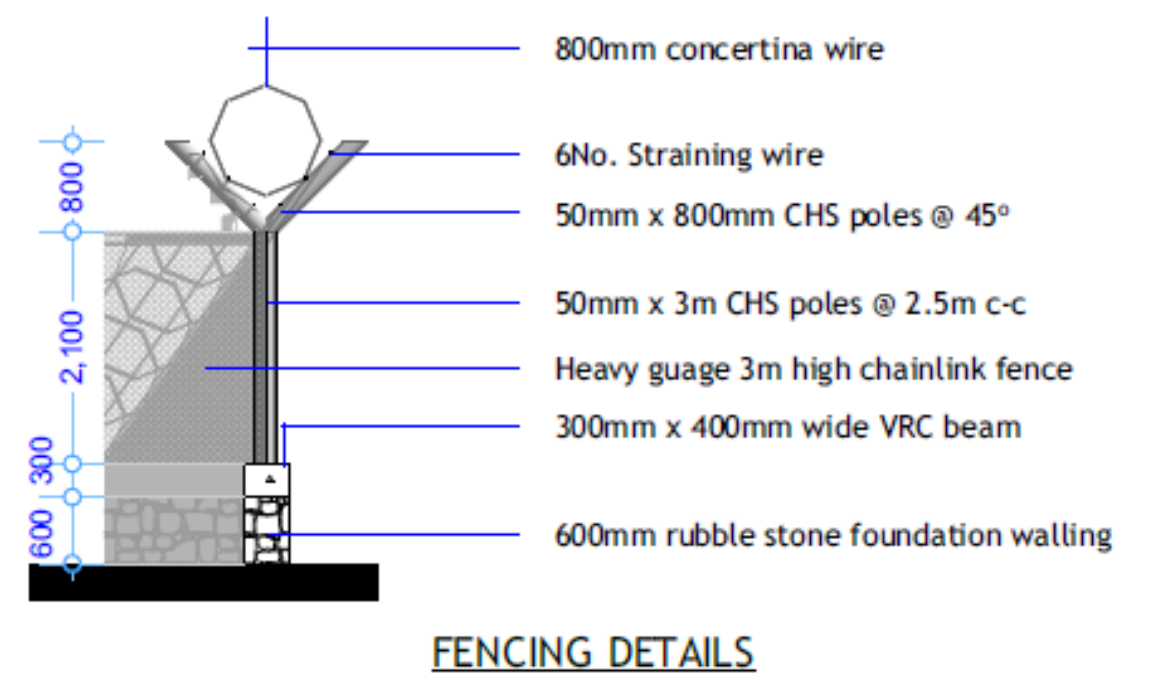
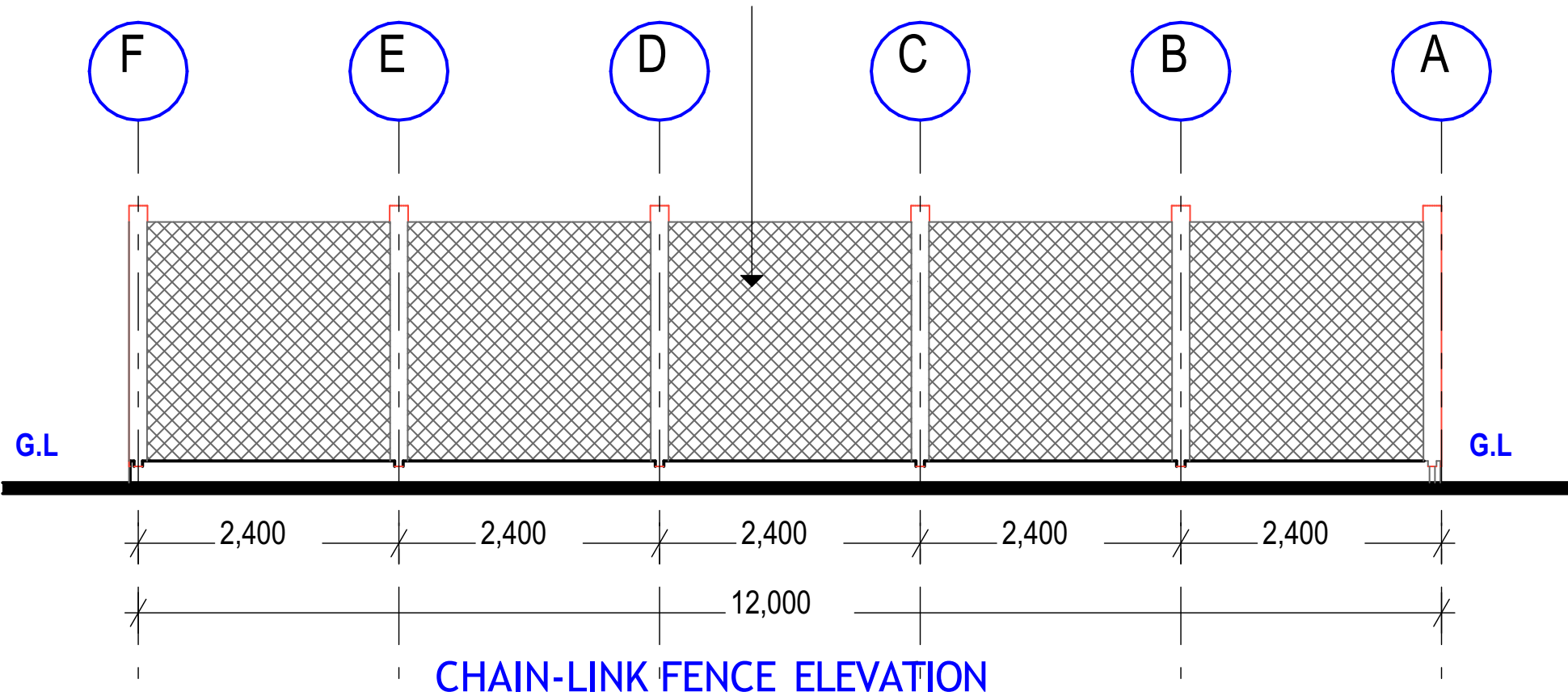

<p><b>GENERAL NOTES</b></p> <ol style="list-style-type: none"> <li>1. All dimensions are in mm unless stated.</li> <li>2. All dimensions to be checked and confirmed on site before commencement of any work.</li> <li>3. Any discrepancy to be reported to the engineer promptly before proceeding.</li> </ol>	<p><b>PROJECT</b></p> <p style="text-align: center;">REHABILITATION WORKS</p>	<p><b>IMPLEMENTING AGENCY</b></p> <p>International Organization for Migration (IOM) The UN Migration Agency</p>	<p><b>DEPARTMENT</b></p> <p style="text-align: center;">WATER SANITATION AND HYGIENE <b>WASH</b></p>	<table border="1" style="width: 100%; border-collapse: collapse;"> <tr><td>SCALE</td><td></td></tr> <tr><td>DATE</td><td>JUNE 2020</td></tr> <tr><td>DESIGNED BY:</td><td>ENG. Wanja.D</td></tr> <tr><td>DRAWN BY:</td><td>ENG. Wanja.D</td></tr> <tr><td>REVIEWED BY:</td><td></td></tr> <tr><td>APPROVED BY:</td><td></td></tr> </table>	SCALE		DATE	JUNE 2020	DESIGNED BY:	ENG. Wanja.D	DRAWN BY:	ENG. Wanja.D	REVIEWED BY:		APPROVED BY:		<table border="1" style="width: 100%; border-collapse: collapse;"> <tr><td><b>DRAWING TITLE:</b></td><td><b>SOLAR LAYOUT</b></td></tr> <tr><td><b>DRAWING N<sup>o</sup>:</b></td><td></td></tr> <tr><td><b>PROJECT N<sup>o</sup>:</b></td><td></td></tr> <tr><td><b>SHEET N<sup>o</sup>:</b></td><td></td></tr> </table>	<b>DRAWING TITLE:</b>	<b>SOLAR LAYOUT</b>	<b>DRAWING N<sup>o</sup>:</b>		<b>PROJECT N<sup>o</sup>:</b>		<b>SHEET N<sup>o</sup>:</b>	
SCALE																									
DATE	JUNE 2020																								
DESIGNED BY:	ENG. Wanja.D																								
DRAWN BY:	ENG. Wanja.D																								
REVIEWED BY:																									
APPROVED BY:																									
<b>DRAWING TITLE:</b>	<b>SOLAR LAYOUT</b>																								
<b>DRAWING N<sup>o</sup>:</b>																									
<b>PROJECT N<sup>o</sup>:</b>																									
<b>SHEET N<sup>o</sup>:</b>																									